

frontrow™

CB6000



INSTALLER GUIDE

YOU'RE ABOUT TO MAKE LEARNING MORE ACCESSIBLE

Welcome to FrontRow — the teacher- and tech-friendly way to improve the learning environment in every classroom.

To make your installation of the FrontRow CB6000 as efficient as possible, we recommend that you first read the section in this guide called **Before You Begin**, and from there proceed to Steps 1 through 6.

If you follow the steps set out in this Installer Guide and organize everything you need beforehand, you'll find setting up your FrontRow CB6000 touch control panel to be quite simple. Of course, if you run into any obstacles, you can always find contact information for our technical support representatives at www.gofrontrow.com/contact-us.

Thank you for choosing FrontRow! You're just steps away from a more productive classroom.

CONTENTS

Step 1..... Pages 1-5
Before You Begin

Step 2.....Page 6
Get Your Configuration Files

Step 3..... Pages 7-12
Configuring Your CB6000s

Step 4.....Page 13
Physical Installation Prep

Step 5.....Page 14
Plan Your installation

Step 6..... Page 15-16
Install Your CB6000

Appendix A..... Page 17-23
Control Logic Programming

Appendix B..... Pages 24-26
Creating Your Own User Interface

Appendix C..... Page 27-31
Setting Preferences

Appendix D.....Page 32
CM3000 Commands

Appendix E.....Page 33
CA1000 Commands

Appendix F.....Page 34
Troubleshooting

Read Me

Be sure to read the helpful tip boxes found throughout this guide. Of course, if you need further assistance, you can always call us at one of the numbers found on the back page.

Step 1: Before you begin

Make sure you've got everything you need to install your FrontRow CB6000. By taking the time to prepare, you'll help ensure the actual set-up is as quick and problem-free as possible.

1. Visualize your goal

When your FrontRow system CB6000 is installed, it may look something like this:

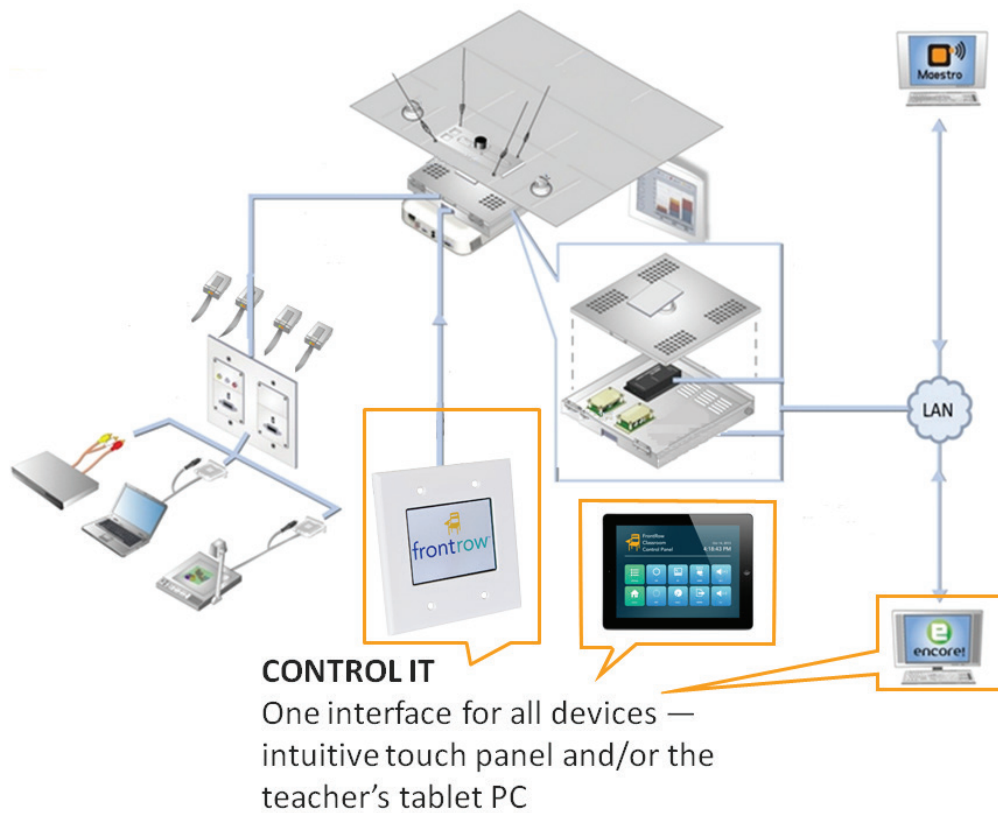

The CB6000 can also be paired with FrontRow Teacher Edition for iOS to control the classroom from an iPad or iPhone. Available on the App Store, Teacher Edition instantly supports all the actions and buttons you program into the CB6000, making it easy to configure, and easy for teachers to learn and use.

Download the Teacher Edition for iOS Setup Guide from the FrontRow website for instructions on configuring an iPad with the CB6000.

2. Get familiar with the touch screen

Main Screen

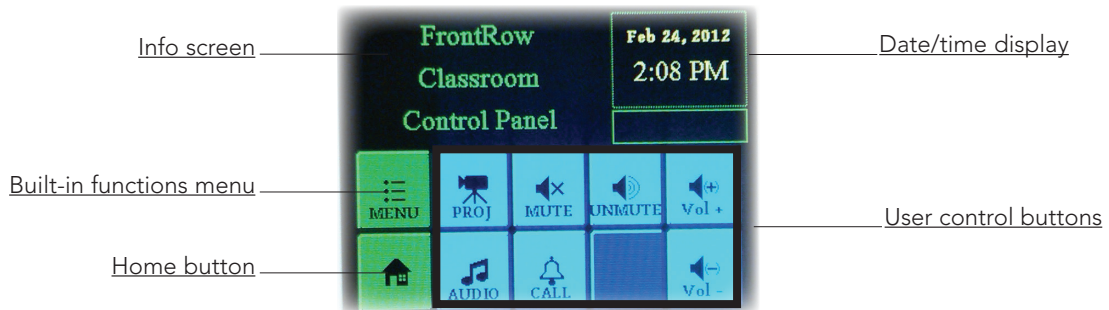

Menu Screen

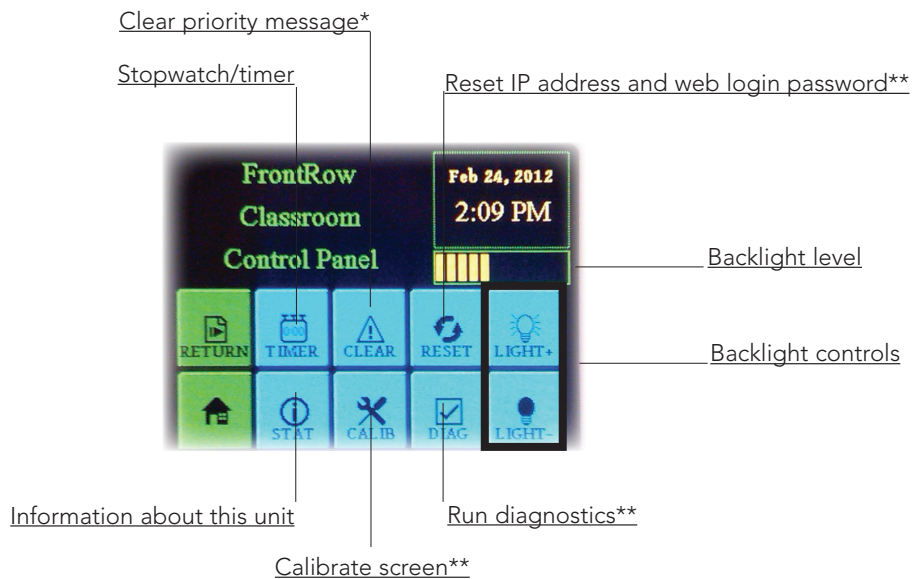

*Password required. Use either installer password (1538) or touch panel password (default is 1357; see Appendix C.7)

**Password required. Use installer password (1538)

Back of CB6000

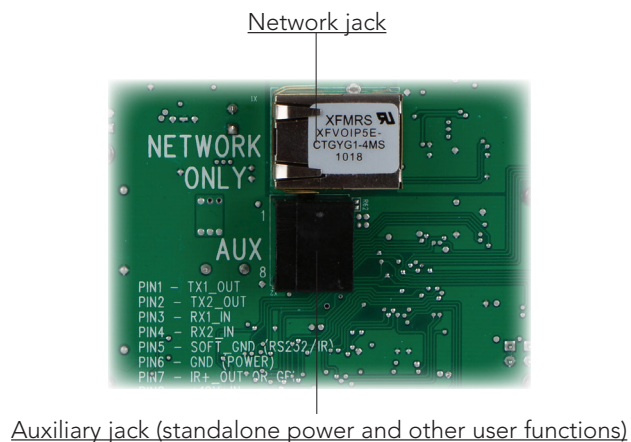

3. What do you want to control? How do you want to control it?

Your CB6000 can let teachers control or communicate with practically any device or person. Now is the time to plan what you want to do.

Example 1: Typical ezRoom setup with projector

In this example, the CB6000 works with other ezRoom components to turn a projector on and off, switch inputs, handle the transport controls for a DVD player, and control audio volume from the teacher's computer, an MP3 player, and two FrontRow wireless microphones. If FrontRow Conductor™ is being used in the school, the CB6000 could also initiate intercom calls and trigger alerts.

Typical ezRoom Wiring

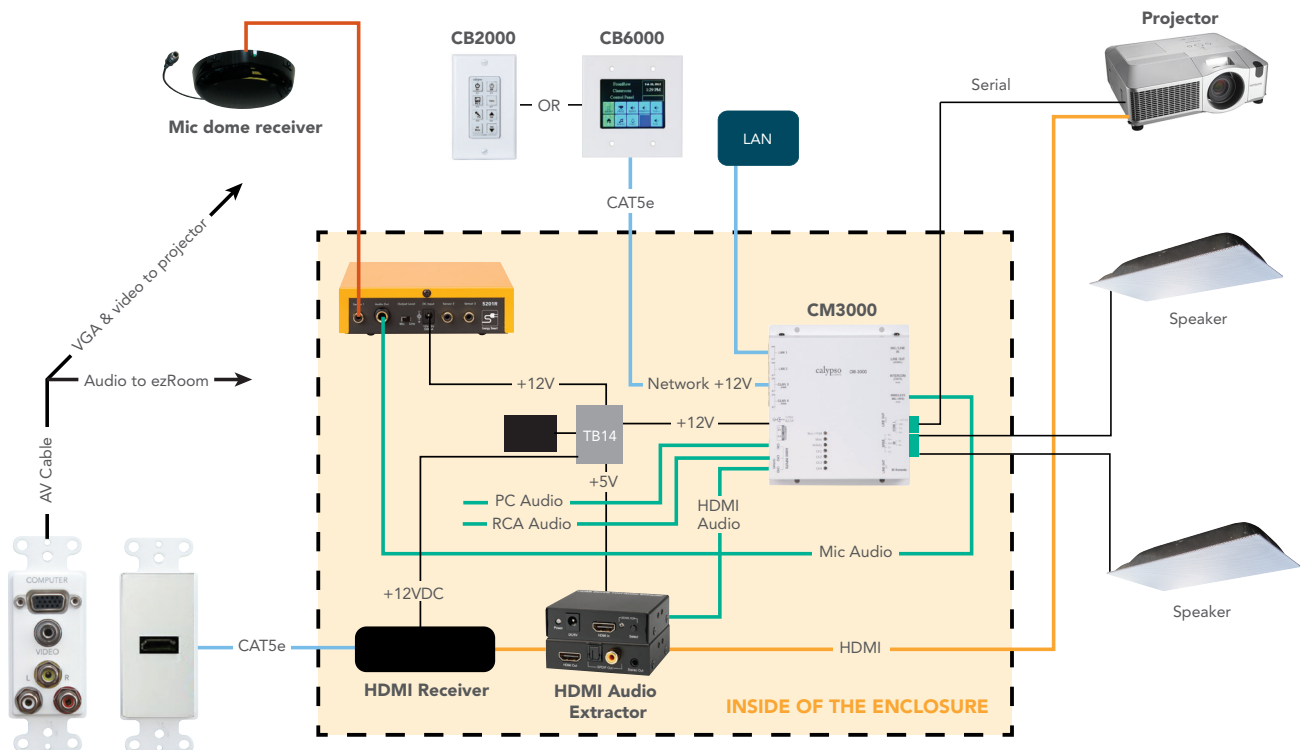

Example 2: Using CB6000 as a stand-alone controller

You can also use the CB6000 as a stand-alone serial controller. In this configuration, the FrontRow TB14 adapter included with your CB6000 standalone kit supplies power, routes commands, and feeds data back (in the case of bidirectional serial devices). In combination with powerful tools like FrontRow Maestro™, this can allow you to 'network' and manage projectors that are otherwise not online. Below are the basic connections for controlling a projector and amplifier serially, and a DVD player via infrared remote.

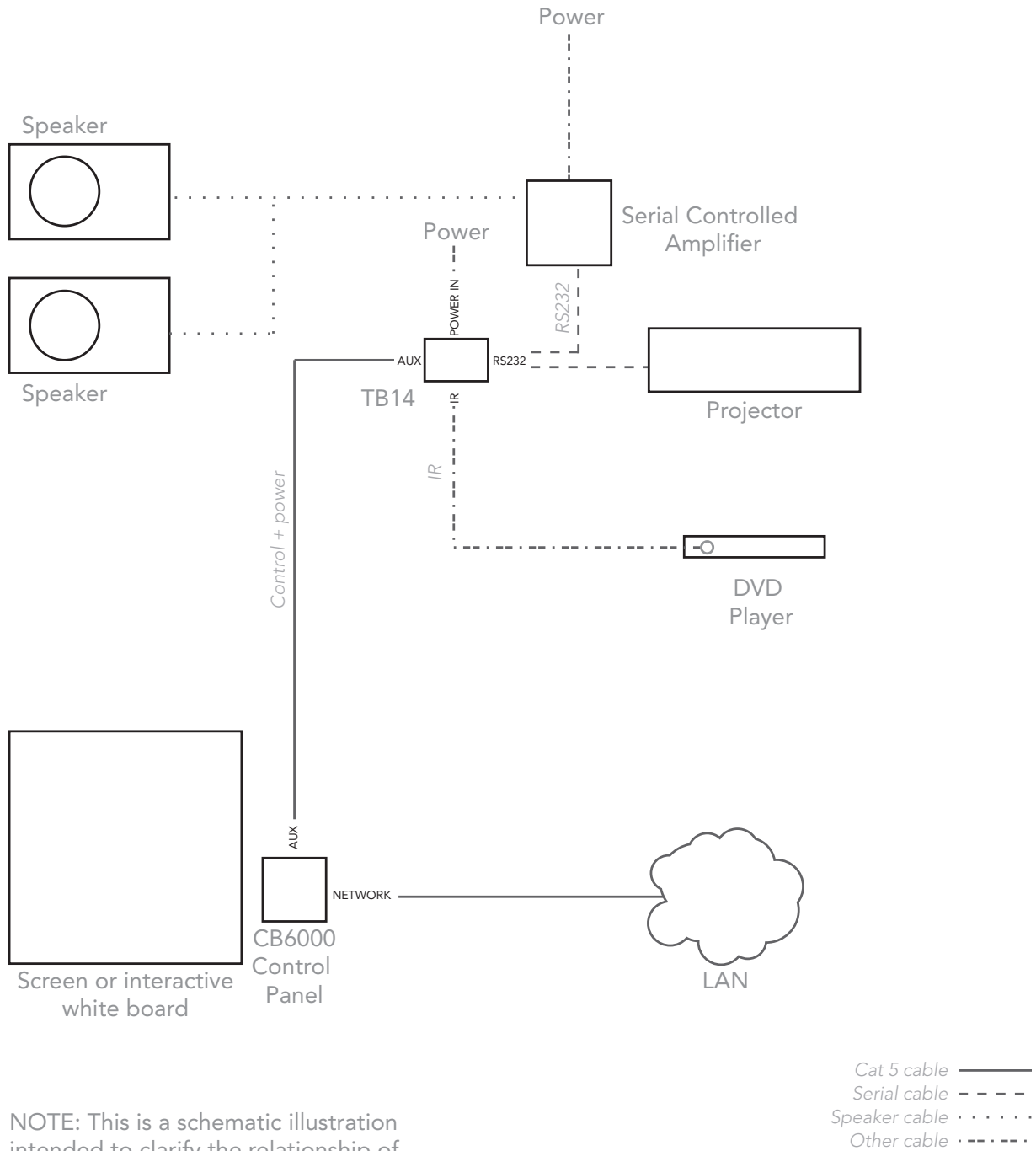

Step 2: Getting Your Configuration Files

Your CB6000s need a script to tell them what the user interface should look like, what other devices they need to communicate with, and how. If your configuration — the collection of commands you want to issue from the CB6000 and the devices you want to control — is the same in each room in your installation, then you will need only one configuration base file which you will modify with specific IP addresses unique to each room. If the situation is different from room to room, you will need different base files that are tailored to each configuration.

There are several ways to create your configuration files:

- Go to gofrontrow.com/base-files and find the Base Configuration File library. Each Base Configuration File stored here includes both the user interface and control logic programming needed for the most common applications.
- If your configuration is uncommon enough that it's outside the scope of the Base Configuration File library, and you have some basic familiarity with programming, you can easily build your own user interface designs or control logic programming. See Appendices A, B, and C for a detailed description of how to do this.

Step 3: Configuring Your CB6000s

Estimated time for this step: 5-10 minutes per CB6000

Here's where you wake up your CB6000s and let them know what their mission is. You can of course reconfigure them at any point if your setup changes or you make a mistake — but it's best to plan ahead so that you don't have to (see Step 1).

For greatest efficiency, we recommend configuring your CB6000s all at once in the office prior to going to the installation site, but you can also do it room by room at the school if you prefer.

1. Gather your configuration tools

To configure your CB6000s, you will need to collect:

- Your CB6000s
- Any of the following power sources:
 - 1 FrontRow CM3000 amplifier/switch with power supply (included in most full ezRoom systems); or
 - 1 FrontRow Soundpost with power supply; or
 - 1 FrontRow TB14 adapter with power supply (included in the kit for using the CB6000 as a stand-alone controller)
- 2 lengths of Cat 5 cable (one of these must be a crossover cable if using the TB14 as a power source — see 2.b below)
- A computer with RJ45 connection and a web browser installed
- A completed ezRoom Installer Planning Template or other detailed information about the school's available IP addresses for your CB6000s, CM3000s, and other components (see Step 1)
- Your Base Configuration File(s) (see Step 2)
- Masking tape or labels and a marker

2. Connect your configuration setup

Take your first CB6000 and connect it to your configuration equipment in either of the ways shown here:

a. With CM3000 or Soundpost as power source

WARNING: CONNECT THE CM3000 OR SOUNDPOST TO THE CB6000'S 'NETWORK ONLY' JACK! YOU CAN DAMAGE YOUR DEVICES IF YOU CONNECT TO THE 'AUX' JACK.

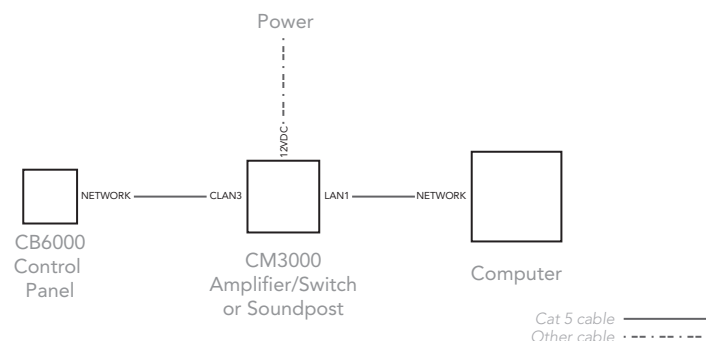

NOTE: This is a schematic illustration intended to clarify the relationship of components to each other. The location of jacks shown here may not reflect their true position on specific devices.

b. With TB14 as power source

WARNING: CONNECT THE TB14 TO THE CB6000'S 'AUX' JACK! YOU CAN DAMAGE YOUR DEVICES IF YOU CONNECT TO THE 'NETWORK ONLY' JACK.

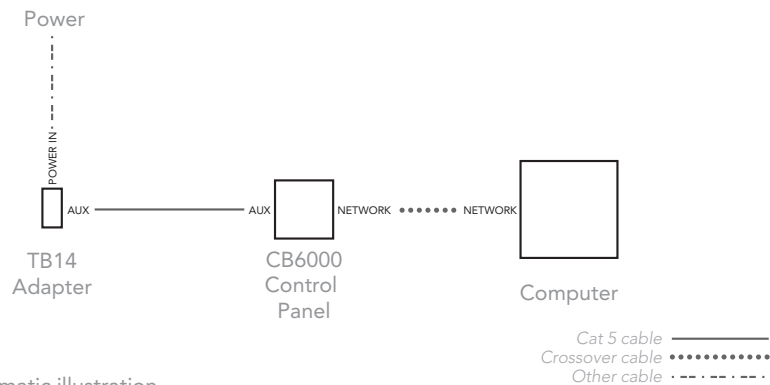

NOTE: This is a schematic illustration intended to clarify the relationship of components to each other. The location of jacks shown here may not reflect their true position on specific devices.

3. Give your computer a static IP address

For the duration of the configuration, your computer needs to have a specific IP address. Here's how to change your computer's wired network adapter from automatic (DHCP) to fixed (static):

a. Windows XP

1. Open **Windows Start** menu.
2. Open **Control Panel**.
 - Classic view: Open **Network Connections**
 - Category view: Select **Network and Internet Connections**, and then **Network Connections**.
3. Double-click on your active LAN or Internet connection.
4. Click **Properties**. This opens the Local Area Connections Properties window. Proceed to 3c.

b. Windows 7

1. Open **Windows Start** menu. Type "network and sharing" into the Search box in the Start Menu and select **Network and Sharing Center** when it comes up.
2. When the Network and Sharing Center opens, click on **Change adapter settings**.
3. If you have a wireless internet connection active, right-click on the icon and temporarily disable this connection for best results.
4. Right-click on your active LAN or Internet connection and select **Properties**. This opens the Local Area Connections Properties window.

c. Local Area Connections Properties (Windows)

1. In the General tab, highlight the **Internet Protocol Version 4 (TCP/IPv4)** or **Internet Protocol (TCP/IP)** item, and click **Properties**.

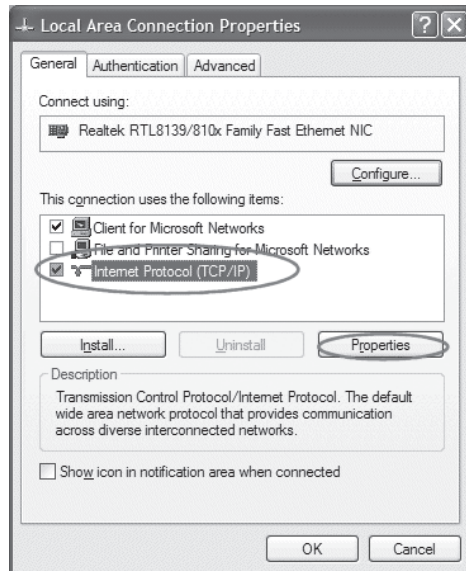

This opens the Internet Protocol (TCP/IP) Properties window.

6. In the General tab, click **Use the following IP address**, and enter:
 - IP address: 192.168.1.100
 - Subnet mask: 255.255.255.0
 - Default gateway: Leave blank

NOTE: We recommend 192.168.1.100 as the standard IP address; however, you may need to use a different address if you are using a local switch already using this address

7. Leave the **Use the following DNS server addresses** fields blank
8. Click **OK**.

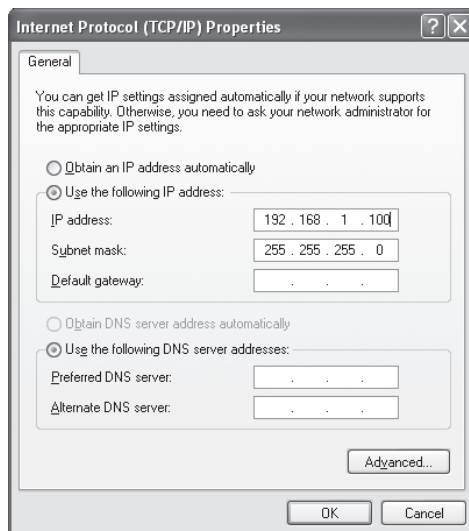

9. Click **OK** to close each window

d. Mac OS X

1. Click the **Apple** icon in the upper left hand corner of your screen.
2. Click the **System Prefreneces..** option
3. In the **Internet & Network** section click the **Network** icon.
4. Select the network connection you use to connect to the internet — the one that has a green dot in front of it. The green dot means the connection is active.
5. Click the **Configure** button which is close to the bottom of the screen
6. Click the **Configure IPv4** drop down box and select the **Manually** option.
7. Enter:
 - IP address: 192.168.1.100
 - Subnet mask: 255.255.255.0
 - Router: Leave blank

NOTE: We recommend 192.168.1.100 as the standard IP address; however, you may need to use a different address if you are using a local switch already using this address

8. Click **Apply Now**.

4. Load the configuration

1. Open a web browser and type in 192.168.1.104 as the URL
2. The CB6000 configuration screen will appear
3. Select **Save/Restore**
4. Select **Browse** and locate your Base Configuration File for this CB6000
5. Check the box if you want the IP address contained in the loaded configuration file to overwrite the IP address on your connected CB6000 unit (useful if you are restoring a file that you know has the correct IP address for this unit). This will allow you to skip points 12 through 14 below.
6. Click **Load**. Note that if you checked the box in point 5 above, the address of the CB6000 may change and you will no longer be connected to it. You'll need to enter the new address in your browser before continuing to point 7.
7. If you are sending commands over the network to a CM3000 amplifier/switch (as is common in an ezRoom system), Soundpost, or other IP-addressable device, click **Macro Definitions**
 - Your Base Configuration File contains variables that reference the IP addresses and ports of the devices you'll be sending commands to. Rather than repeating the addresses throughout the script and having to update all of these as we configure each new room, we use a Macro Name variable in the script that can be used in all rooms. You will simply change the definition of that variable for each room installation.
 - Your Base Configuration File will have at least one Macro Name defined, indicating the device to be commanded from the CB6000.
 - Replace the IP address portion of the Macro Value Field with the appropriate IP address for that device in the room you're working on. (Reference your Installer Planning Template; see Step 1)
 - Click **Save Macros**

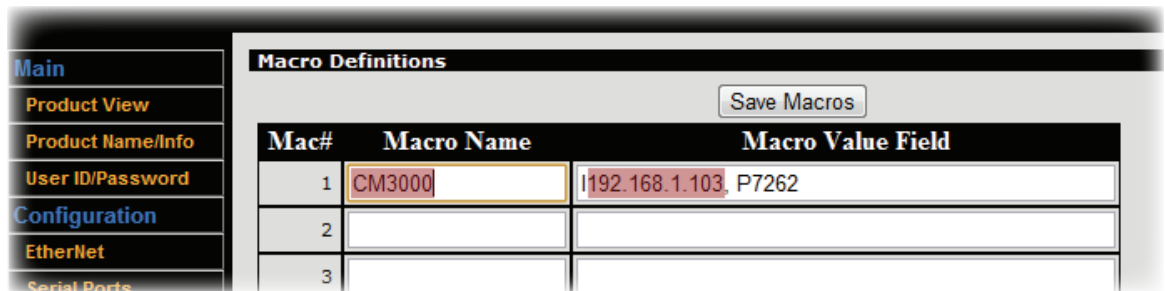

Tip

To save time on future configuration jobs, create a shortcut on your desktop to 192.168.1.104 and name it CB6000 Configuration Screen.

If using the Apple Safari browser, do not use password protection during reload. For best results, FrontRow recommends using the Google Chrome browser.

8. Select **Time** from the left-hand menu
9. Click **Load Computer Time**
10. Check the option box **Display clock in 24-hour format** to have the display time in the 24 hour format (if not checked, the time will be displayed in a 12 hour format).
11. Click **Save Settings**

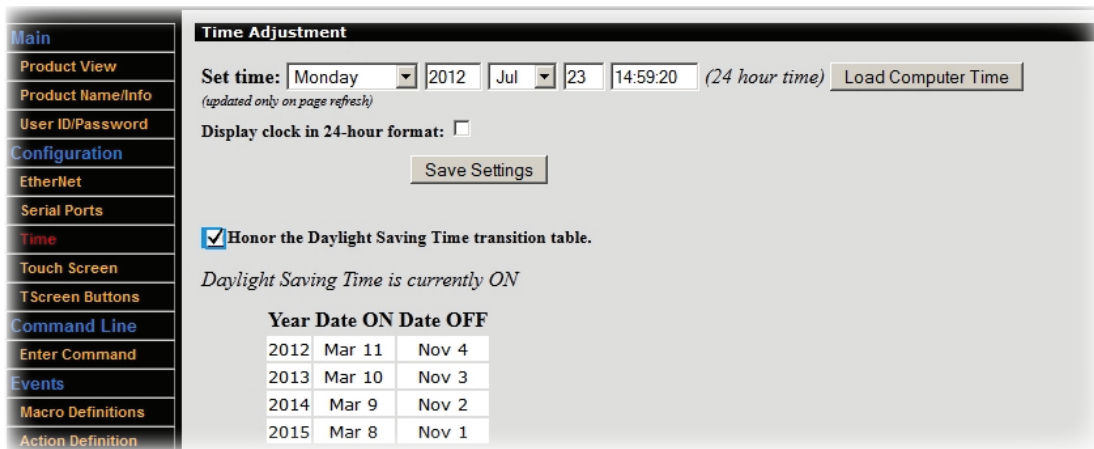

12. Now define the IP address of this CB6000. Select **Ethernet** from the left-hand menu
13. Change the IP address, subnet mask, and router IP address to the appropriate values for this CB6000 (Reference your Installer Planning Template; see Step 1)
14. Click **Save Settings** (your browser will likely timeout; this is normal)

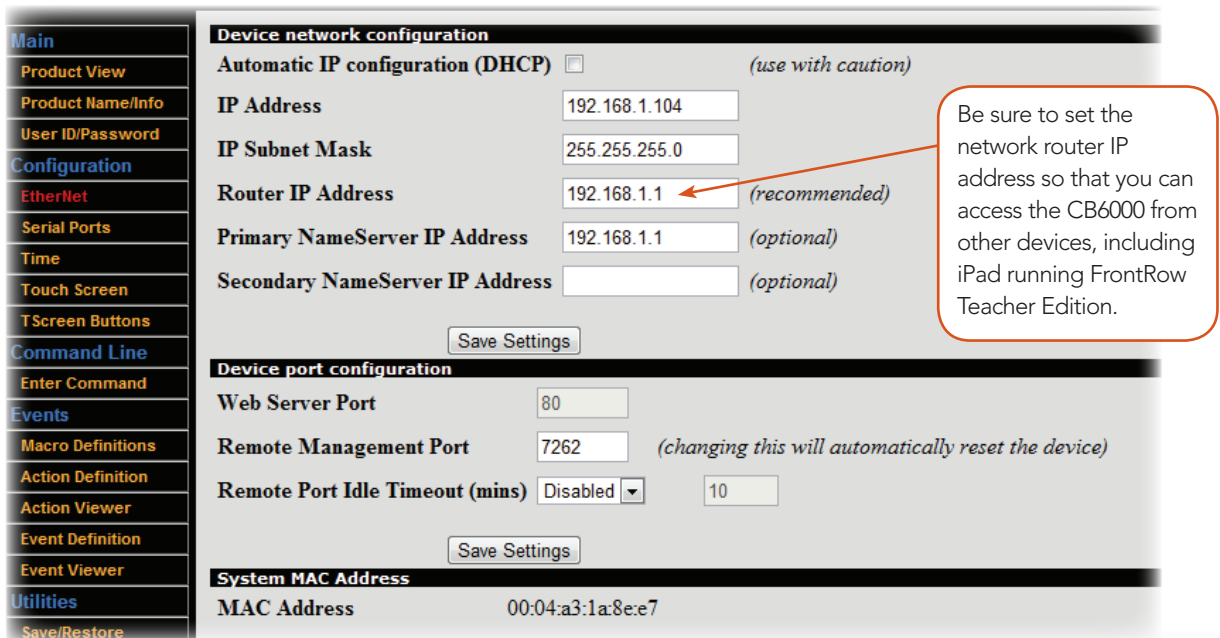

15. Disconnect the CB6000 from the Cat 5 cable, replace it in its anti-static bag, and apply a label with the room number written on it so you are sure to install it in the right place on the job site.
16. Connect your next CB6000 and repeat Step 3.4 'Load the Configuration' until all of your units are programmed. Note that on some Windows® computers, you may need to clear the ARP cache in order to communicate with the next device. See Appendix F.

Step 4: Physical Installation Prep

Nearly everything you need to install your FrontRow CB6000s is included in the boxes we shipped. You will need some basic tools and materials, depending on how your classroom is built:

1. Materials you will need

- For each CB6000: US-standard double-gang AV box, electrical box, surface box, or mud ring
- Plastic raceway with screws (if not routing cable inside wall)
- Plastic cable (zip) ties
- Cable tacks/staples

2. Recommended tools

- Drill (or hammer drill for concrete walls)
- Drill bits (or masonry bits for concrete walls)
- Slotted screwdriver
- Level or ruler/tape measure
- Crimp pliers or scissors
- Tin snips (optional)
- Ladder
- Staple gun
- Safety goggles

General safety precautions

- Do not install or use the CB6000 near water or heat sources
- Clean only with a dry cloth
- Protect all cables from wear and damage from doors and other hazards
- Use only accessories specified by FrontRow
- Refer servicing to qualified service personnel
- Wear safety goggles when using power tools

Step 5: Plan your installation

Estimated time for this step: 5-10 minutes

Now it's time to decide where you'll place the CB6000 (note that if your installation is part of an ezRoom, be sure to refer to the Installer guides for the various ezRoom components for best results). To help you decide, we'll use the following layout of a typical classroom as an example:

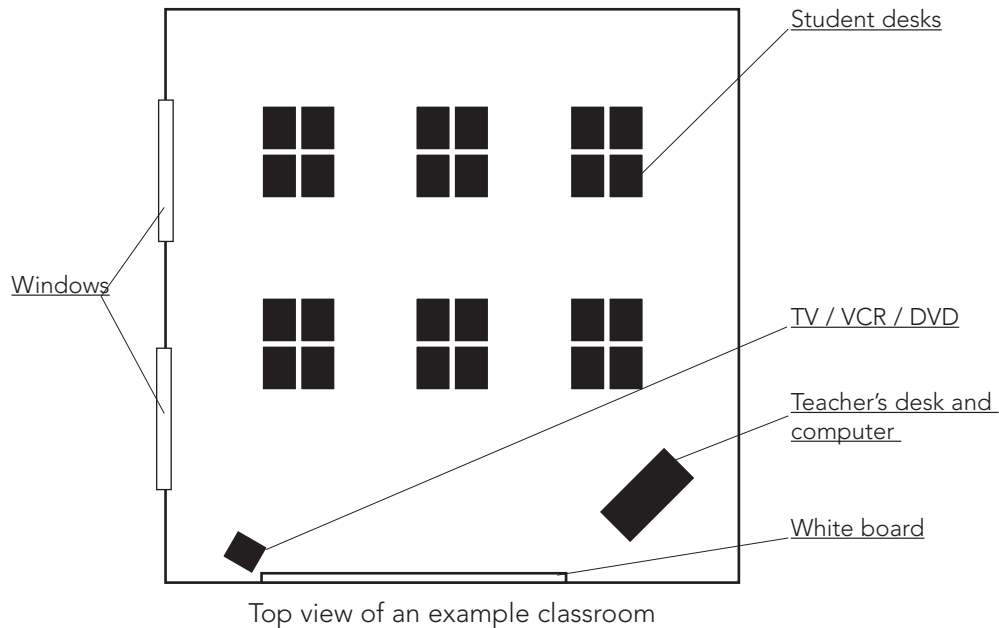

1. Decide where to put the CB6000

We recommend locating the CB6000 where the instructor is likely to spend most of her or his time. In the example below, we've placed the CB6000 conveniently near both the whiteboard and the teacher's desk.

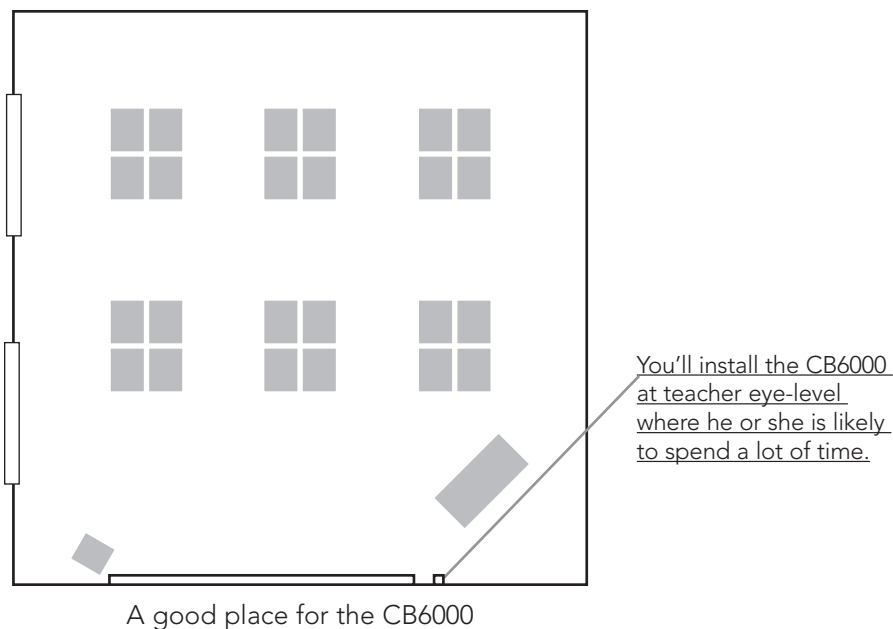

Tip

If using the TB14 to control devices via IR signaling, remember that a cable length of 12m/40ft is allowed — so select your CB6000 position accordingly.

Step 6: Install your CB6000

Estimated time for this step: 15 minutes

With the positions and programming of all your major components settled, you can now install your CB6000s. **Refer to the examples in Step 1 as you connect components.**

1. Install a double-gang electrical box, surface box, or mud ring according to the manufacturer's instructions
2. If using the CB6000 with a FrontRow CM3000 amplifier/switch (as in a full ezRoom system):
 - Thread Cat 5 cable from the electrical box to the location of the FrontRow CM3000. Ensure the cable is installed in compliance with your national and local electrical codes.
 - Connect the Cat 5 cable to the CB6000's **Network** jack

WARNING: CONNECT TO THE CB6000'S "NETWORK ONLY" JACK! YOU CAN DAMAGE YOUR DEVICES IF YOU CONNECT TO THE "AUX" JACK.

- If you are controlling a serial device (e.g., projector), connect the provided serial cable(s) to the CM3000's **COM1** captive screw connector. Wiring is as follows:
 - Black (ground) to GND
 - Red (input to device) to TX1
 - White (output from device) to RX1

IMPORTANT: Be sure to keep wiring and Action commands consistent to avoid problems. For example, serial Actions sent to COM1 should use the TX1/RX1 pins. (See Appendix A).

- If you are controlling a device via infrared (e.g., a DVD player), connect an IR emitter cable (not included; part number 520-3001-001) to the TB5 IR Emitter Cable Extension Adapter (not included; part number 310-2546-120) and connect the TB5 to the CM3000's **IR** captive screw connector. Secure the emitter end to the controlled device's infrared sensor.
 - Connect the Cat 5 cable to one of the **CLAN** jacks on your CM3000
3. If using the CB6000 with a FrontRow Soundpost:
 - Thread Cat 5 cable from the electrical box to the location of the FrontRow Soundpost. Ensure the cable is installed in compliance with your national and local electrical codes.
 - Connect the Cat 5 cable to the CB6000's **Network** jack

WARNING: CONNECT TO THE CB6000'S "NETWORK ONLY" JACK! YOU CAN DAMAGE YOUR DEVICES IF YOU CONNECT TO THE "AUX" JACK.

- If you are controlling a serial device (e.g., projector), connect a Cat 5 cable between the Soundpost's **AUX1** RJ45 jack and a TB232 adapter (not included; part number 600-10-2001). Connect the TB232 adapter to the controlled device's serial port.
- Connect the Cat 5 cable to the **CLAN** jack on your Soundpost

4. If using the CB6000 as a standalone controller with the TB14 adapter:
 - Mount the TB14 adapter securely near the projector or other device to be controlled.
 - Thread Cat 5 cable from the electrical box to the location of the TB14 adapter. Ensure the cable is installed in compliance with your national and local electrical codes.
 - Connect the Cat 5 cable to the CB6000's **AUX** jack

WARNING: CONNECT TO THE CB6000'S "AUX" JACK! YOU CAN DAMAGE YOUR DEVICES IF YOU CONNECT TO THE "NETWORK ONLY" JACK.

- If you are controlling a serial device (e.g., projector), connect the provided serial cable(s) to the TB14 adapter's **RS232** captive screw connector. You can have up to two separate serial cables. Wiring is as follows:

- To control the first device:
 - Black (ground) to Pin 3/GND
 - Red (input to device) to Pin 2/TX1 OUT
 - White (output from device) to Pin 1/RX1 IN
- To control a second device:
 - Black (ground) to Pin 3/GND
 - Red (input to device) to Pin 5/TX2 OUT
 - White (output from device) to Pin 4/RX2 IN

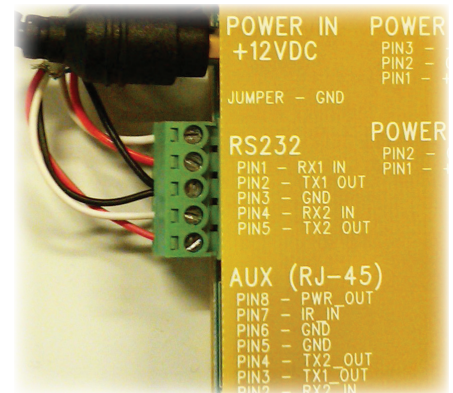

IMPORTANT: Be sure to keep wiring and Action commands consistent to avoid problems. For example, serial Actions sent to COM1 should use the TX1/RX1 pins; actions sent to COM2 should use the TX2/RX2 pins. (See Appendix A.)

- If you are controlling a device via infrared (e.g., a DVD player), connect an IR emitter cable (not included; part number 520-3001-001) to the TB14's IR jack and secure the emitter end to the controlled device's infrared sensor. You can control up to two separate infrared devices.
 - Connect the power supply to the TB14 adapter
 - Connect the Cat 5 cable to the **AUX** jack on the TB14 adapter
5. Confirm that button presses result in the expected actions. If there are any errors, check wiring and confirm configuration control logic. (Refer to Step 3 and Appendix A as needed.)
 6. Screw the CB6000 panel into the electrical box with the screws provided

CAUTION: DO NOT OVER-TORQUE SCREWS WHEN MOUNTING CB6000 — THIS CAN DAMAGE THE LCD SCREEN.

7. Check for good responsiveness of buttons to touch; if needed, recalibrate using the built-in calibration tool (see Step 1.2)

Appendix A: Control Logic Programming

You can use the CB6000 to its full potential by learning to program your own configuration files. Each CB6000 includes a utility for creating, modifying, loading, and/or saving the configuration file. We strongly recommend that you use the following workflow for any custom programming:

1. Create Macros (covered in Appendix A.2) — Variables that refer to specific IP-addressable devices
2. Create Actions (covered in Appendix A.3) — Specific control commands for specific devices
3. Create Events (covered in Appendix A.4) — The kinds of situations in which you want to initiate one or more Actions
4. Create Pages (covered in Appendix B) — Logical groupings of buttons (e.g., DVD transport controls)
5. Create Buttons (covered in Appendix B) — Buttons that represent specific Events (e.g., mute)
6. Set Preferences (covered in Appendix C) — Set other parameters (e.g., timeout, security)

You can certainly deviate from this workflow, but you will probably waste some time flipping back and forth between programming screens unnecessarily.

7. Connect to the CB6000 through A Web Browser

On a computer connected to the LAN, type in the IP address of your CB6000 — the default is 192.168.1.104. If you have not already reassigned it (see Step 3 for guidance).

8. Define Macros

Defining Macros makes mass deployment of CB6000s easier by letting you define Actions using variables to represent the IP addresses of the devices you'll control. This means that your configuration file can be written as a template, with IP addresses explicitly defined in only one place (the Macro Definitions) rather than repeated throughout your Actions. This saves a tremendous amount of labor as you re-use the configuration file to control new devices from room to room.

- Choose **Macro Definitions**
- Enter up to 16 macro names and values in the following format:
 - **Macro Name:** Any name can be used, but it is most useful if this is an easily recognizable, generic, and concise name for a device type used throughout your installation (e.g., CM3000, Projector, etc.)
 - **Macro Value Field:** The value of this variable for this particular installation. For NET commands (see Appendix A.3) this takes the format:

ipaddress,Pport (e.g., I192.168.1.201,P7262)

For HTP commands (see Appendix A.3) this simply takes the format:

ipaddress (e.g., 192.168.1.201)

- Click **Save Macros**.

The Macro definitions are included as part of the saved configuration file. When you use this configuration file as a template in similar installations, simply change the value of each defined Macro to the appropriate IP address. For example, in subsequent rooms, we may set the value of 'CM3000' to I192.168.1.202,P7262; I192.168.1.203,P7262; and so on.

Mac#	Macro Name	Macro Value Field
1	CM3000	I192.168.1.103, P7262
2		

9. Create Actions

Actions are specific instructions that are sent to specific devices. Once defined, you will link them to various Events for execution (see Appendix A.4)

To create or edit an Action:

- Select **Action Definitions**. (Note that it may be more convenient to navigate to previously defined Actions via the **Action Viewer**.)
- You can move through various Actions using the buttons at the top of this screen. (**CAUTION: Save your work on the current Action before navigating away or your changes will be lost!**)
 - **Edit New Action:** Lets you modify the Action definitions for a saved Action.
 - **Paste to New Action:** Useful for cloning the current Action (displayed in the black strip labeled "Currently editing Action Number xx.") to another Action. Change the New Action field to the number of the target Action and click the Paste to New Action button. The current Action data will be copied to the target Action. (**CAUTION: This will overwrite the target Action!**)
 - **Edit Previous Action:** Moves to the previous Action record
 - **Edit Next Action:** Moves to the next Action record.
 - **Edit Next Empty Action:** Moves to a new undefined Action record.
 - **Edit Next Defined Action:** Moves to the next defined Action (skipping over any undefined records)
- Give the Action a brief, useful description (e.g., "Net Mute")
- Define the Action using **Action Command**:
 - Select a template for the Action from the drop-down list:
 - NET Command — For commands to be sent to IP-addressable devices over your network
 - HTP Command — To initiate an intercom call via a FrontRow Conductor™ server to a FrontRow CM3000 elsewhere on the network (e.g., the office or another classroom). For schools using the Conductor™ IP paging and bell system only.
 - Serial Transmit — For commands to be sent directly to serial devices using RS232 protocol
 - IR-Out Universal Command — For commands to be sent directly to devices that can only be controlled via infrared remote
 - Alarm Command — For use with FrontRow CM3000 only. Initiates a beep with a short delay.
 - NOP Command — Effectively deletes an Action that was previously defined.
 - Use the syntax template that appears to build the specific Action you want

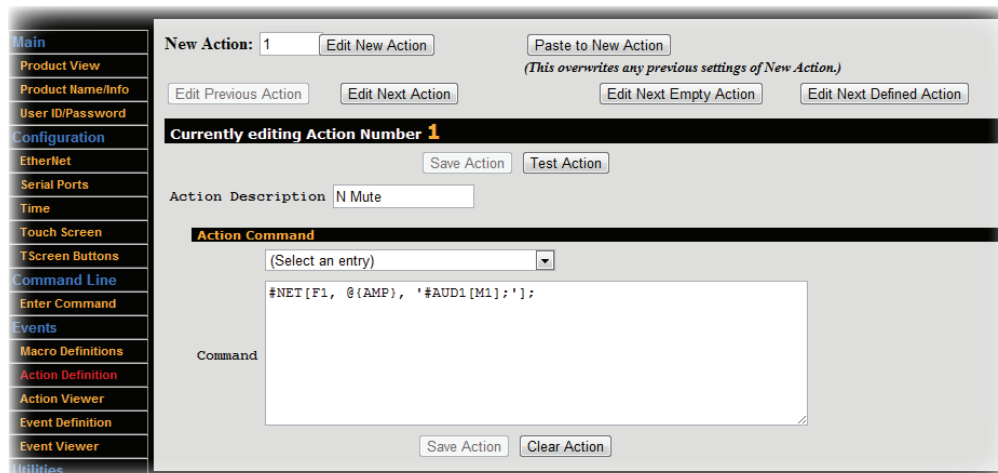

The screenshot shows the 'Action Definition' interface. On the left is a sidebar menu with options: Main, Product View, Product Name/Info, User ID/Password, Configuration, Ethernet, Serial Ports, Time, Touch Screen, T Screen Buttons, Command Line, Enter Command, Events, Macro Definitions, Action Definition (highlighted), Action Viewer, Event Definition, Event Viewer, and Utilities. The main area is titled 'Currently editing Action Number 1'. At the top, it shows 'New Action: 1' with buttons for 'Edit New Action' and 'Paste to New Action'. Below this are buttons for 'Edit Previous Action', 'Edit Next Action', 'Edit Next Empty Action', and 'Edit Next Defined Action'. The 'Action Description' field contains 'N Mute'. The 'Action Command' section has a dropdown menu with '(Select an entry)' and a text area containing the command: '#NET [F1, @{AMP}, '#{AUD1[M1]:}']'. At the bottom are 'Save Action' and 'Clear Action' buttons.

Network (NET) Commands*				
Syntax: #NET[<i>Connection</i> , <i>StringType</i> , <i>Device</i> , ' <i>Command</i> '];				
Name	Required/Optional	Data Type	Format	Description
<i>Connection</i>	Required	Variation	<i>F</i> <i>n</i> where <i>n</i> is 1 or 2	Defines the connection type: <ul style="list-style-type: none"> • TCP/IP (1) • UDP (2)
<i>StringType</i>	Optional	Variation	<i>T</i> <i>n</i> where <i>n</i> is 1 or 2	Defines the string type: <ul style="list-style-type: none"> • ASCII string (1) • Hexadecimal (2) If you leave <i>StringType</i> blank, a default of T1 is assumed.
<i>Device</i>	Required	Variation	If using Macros (recommended): @{ <i>MacroName</i> } For explicit device references: <i>IAddress</i> , <i>PPort</i> Default port for CB6000 is 7267	A string expression that's the valid name of a Macro (see Appendix A.2) or the IP address and port of device to be controlled.
<i>Command</i>	Required	Variation	Specific to device. For CM3000 commands, see Appendix D; for other device commands see manufacturer's instructions.	A string expression that contains the command.
Example (increments the audio input channel of a CM3000 by one over TCP/IP protocol using an ASCII string): #NET[F1, @{CM3000}, #AUD1[+];'];				
Intercom (HTP) Commands*				
Syntax: #HTP[http:// <i>Server</i> /calypso/conductor/?/call/ <i>Device</i>];				
Name	Required/Optional	Data Type	Format	Description
<i>Server</i>	Required	Variation	If using Macros (recommended): @{ <i>MacroName</i> } For explicit device references: IP address of the Conductor server	A string expression that's the valid name of a Macro (see Appendix A.2) or the IP address of the Conductor™ server.
<i>Device</i>	Required	Variation	If using Macros (recommended): @{ <i>MacroName</i> } For explicit device references: IP address of the CM3000	A string expression that's the valid name of a Macro (see Appendix A.2) or the IP address of a CM3000 located on the network
Example (initiates a proxy intercom request from the CM3000 located in the office): #HTP[http://@{DRS5000}/calypso/conductor/?/call/@{OfficeCM3000}];				

Serial (COM) Commands*				
Syntax: #COMn[StringType,"Command"];				
Name	Required/Optional	Data Type	Format	Description
<i>n</i>	Required	Variation	Use 1 for COM1; use 2 for COM2.	Denotes the COM port to be used, corresponding to the serial device to be controlled.
<i>StringType</i>	Optional	Variation	Tn where <i>n</i> is 1 or 2	Defines the string type: <ul style="list-style-type: none"> • ASCII string (1) • Hexadecimal (2) If you leave <i>StringType</i> blank, a default of T1 is assumed.
<i>Command</i>	Required	Variation	Specific to device. For CA1000 commands, see Appendix E; for other device commands see manufacturer's instructions.	A string expression that contains the command.
Example (turns on a projector via COM 1 using an ASCII string command): #COM1[T1,"PWR ON\r"];				
IR-Out Universal Commands*				
Syntax: #XROn[F2,"Command"];				
Name	Required/Optional	Data Type	Format	Description
<i>n</i>	Required	Variation	Use 1 for IR port 1.	Denotes the IR port to be used.
<i>Command</i>	Required	Variation	Specific to device. See the IR Learning section under Appendix A.5 or see manufacturer's instructions.	A string expression that contains the command.
Example (turns on a DVD player): #XRO1[F2," 40000300015430309DA03F508FC03A704D6039...3A704D803F808FC03A704D403A104FB03A704D903"];				
Alarm Commands*				
Syntax: #ALM["Command",DTime];				
Name	Required/Optional	Data Type	Format	Description
<i>Command</i>	Required	Variation	Use ON to start the alarm. Use OFF to stop the alarm.	Starts/stops the beep.
<i>Time</i>	Required	Variation	Integer representing multiples of 4ms duration.	Sets the duration
Example (turns on the beep with a 200ms duration): #ALM["ON",D50];				

*For complete programming guidance, refer to the Calypso Action Control Language (ACL) manual under the Downloads section of the ezRoom web page: www.gofrontrow.com/ezroom.

- If the CB6000 has been physically installed, you can test the action you created by clicking the **Test Action** button. Note that you can also test Actions via the Action Viewer by clicking on the checkmark to the right of each Action. Alternatively, the **Enter Command** screen can be a useful tool for testing and troubleshooting Actions (see Appendix A.6).

10. Define Events

With your collection of discrete Actions defined, you can now specify what Events will cause one or more of those Actions to be executed.

In most cases, a user pressing a button on the touch screen is what tells the CB6000 that an Event has occurred; however, you are also free to specify any general purpose input or NOP signal you wish as a Trigger. Alternatively, you can schedule an Event.

New Event:
(This overwrites any previous settings of New Event.)

Currently editing Event Number 7

Event Description:

Trigger Quicklist:

Event Trigger:

Time Start:

How to run the defined actions: All (in parallel) Each (in order) One per call (in sequence)

2 / 156	Act#	Action Desc	Action Command
<input type="button" value="+"/> <input type="button" value="-"/>	63	C Proj VGA 1	#COM1[T1,"SOURCE 11\r"];
<input type="button" value="+"/> <input type="button" value="-"/>	4	N Channel 1	#NET[F1, @{AMP}, '#AUD1[I1]..
<input type="button" value="+"/>	new		

To create or edit an Event:

- Select **Event Definitions**. (Note that it may be more convenient to navigate to previously defined Events via the **Event Viewer**.)
- You can move through various Events using the buttons at the top of this screen. (**CAUTION: Save your work on the current Event before navigating away or your changes will be lost!**)
 - **Edit New Event**: Lets you modify the Event definitions for a saved Action.
 - **Paste to New Event**: Useful for cloning the current Event (displayed in the black strip labeled "Currently editing Event Number xx.") to another Event. Change the New Event field to the number of the target Event and click the Paste to New Event button. The current Event data will be copied to the target Event. (**CAUTION: This will overwrite the target Event!**)
 - **Edit Previous Event**: Moves to the previous Event record
 - **Edit Next Event**: Moves to the next Event record.
 - **Edit Next Empty Event**: Moves to a new undefined Event record.
 - **Edit Next Defined Event**: Moves to the next defined Event (skipping over any undefined records)
- Give the Event a useful description (e.g., "Mute")
- If you want to have the Event initiated by a button press, you will eventually assign a button to this Event in the **TScreen Buttons** interface (see Appendix B.2)
- If you want to have the Event initiated by a general purpose input signal, make a selection in the **Trigger Quicklist** and define the specific Trigger in the **Event Trigger** field. The CB6000 constantly scans all inputs, searching for an event that matches any Triggers you have defined. When a matching event is recognized, the corresponding output actions are executed in rapid succession.
- If you want to have the Event initiated according to a schedule, select the schedule you'd like using the **Time Start** menu

- You can have multiple Events with the same input trigger. When that defined trigger is detected by the CB6000 all the matching Events will be executed in no particular order. For each such Event, the Actions for the Event will execute according to that Event's mode setting (see below); however, Actions for different Events may be intermingled with each other. If you care about the order in which Actions happen, put them all in a *single* Event and set the mode to *Each*.
- Select the mode in which you would like to run the defined Actions:
 - *All*: the CB6000 will attempt to execute all Actions for that event simultaneously, but in no particular order (e.g., Action 2 and Action 1 and Action 3...)
 - *Each*: the CB6000 will execute all Actions in the order listed (e.g., Action 1, then Action 2, then Action 3...) This is useful when the order matters to you; for example, turning off a projector before retracting a projector screen.
 - *One per call*: the CB6000 will treat the actions as a loop, executing the next Action in the series each time the Event is initiated (e.g., Action 1 on the first button press, Action 2 on the second button press, Action 1 on the third button press, etc.). This is useful for toggle functions like power.
- Assign or remove one or more Actions to this Event using the list under **Current Event Actions**:
 - Click the **+** button and select the desired action from the list that appears below (Note that the order of the Actions in the list matters if you have chosen to run these in *Each* or *One per Call* mode.)
 - To remove an Action, click the **-** button next to the action you no longer want to run

If the CB6000 has been physically installed, you can test the Event you created by clicking the **Test Event** button. (Note that you can also test Events via the **Event Viewer** by clicking on the checkmark to the right of each Event.)

Be sure to **Save** the Event before moving to another section

11. IR Learning

If you are controlling devices that lack serial control ports (the recommended method for controlling non-networked devices) but have an infrared remote control, you can place your CB6000 into an IR learning mode.

- Choose **Enter Command**
- Select one of the 'Learn Universal IR...' options from the drop-down list
- Click **Send CMD**
- Hold the device's IR remote control within 15cm/6in of the CB6000 LCD screen, then press the button on the remote control for the function to be learned
- The IR command string will appear in the **Receive Command** window, and is available for copying and pasting into an Action Definition (see Appendix A.3).

When an IR command is learned the controller inserts an "IR Header" onto the front of the command. Each Hex byte of this header contains information pertaining to certain IR parameters of a learned code. It is not retransmitted with the IR code. It tells the controller what to do with the code string that follows. It is helpful to understand the first 6 bytes of this header when dealing with difficult IR devices.

Example IR header: 40 00 03 00 01 54

BYTE 1: Carrier frequency of the IR command: 28kHz, 30kHz, 32kHz, 36kHz, 38kHz, 40kHz and 56kHz. This byte should not be changed unless there is a need to strip the carrier from the IR signal. This can be accomplished by changing the byte to 00.

BYTE 2: Idle/Delay time – a user adjustable time to override the existing idle gap between IR bursts when the IR command is sent more than once, or to add a delay time after the last IR command burst. Allowable timing increments are 04h – 7Fh for an idle gap override, and 80h - FFh for an added delay time. Each hex unit is equal to 10ms delay. For example, a value of 0Ah (decimal 10) would insert a delay of 100ms between the IR bursts. Default is 00h, which means that the controller will use the idle time that is part of the learned IR code. A value of 90h (decimal 144) would add a 1.44 second delay after the last IR command sent.

BYTE 3: Repeat - selects how many times the IR command is to be repeated. Allowable values are from 01h to FFh (must be in Hex form!). Default is 03h and 00h is invalid.

BYTE 4: Repeat Mode - three selections: 00h = repeat the entire IR command, 01 = repeat the IR header only once, 02h = repeat the IR command with an offset. Default is 00h.

BYTE 5: Offset – displays which section of the IR burst was learned.

01 = Learn Universal code

02 = Learn Universal code w/1 skip

03 = Learn Universal code w/2 skips

BYTE 6: Data Length – displays the size of the data string in Hex form including the header.

12. Enter Command

The Enter Command interface lets you test proper connection and function by entering and executing command strings. You can use this to verify the correctness of a command before you enter it into an Action. For serial commands, it can also be used to see any data returned from the remote device.

- Choose **Enter Command**
- Select a test command from the drop-down menu (the test command will appear in the **Send Command** window):
 - For Serial:
 - Serial Transmit - #COMxx[""] TX
 - Serial Receive - #COMxx[] RX
 - For Infrared:
 - IR-Out Universal Command-#XROxx[F2] output
 - Learn Universal IR code - #XRI1 [F2] input (universal header uses fixed 40K, user can modify)
 - For TCP:
 - NET Command (TCP) - #NET[F1,...]
 - For test command:
 - Alarm Command #ALM["ON"]
- Click **Send CMD**
- The Receive Command field is populated when it receives a response back from a connected serial device

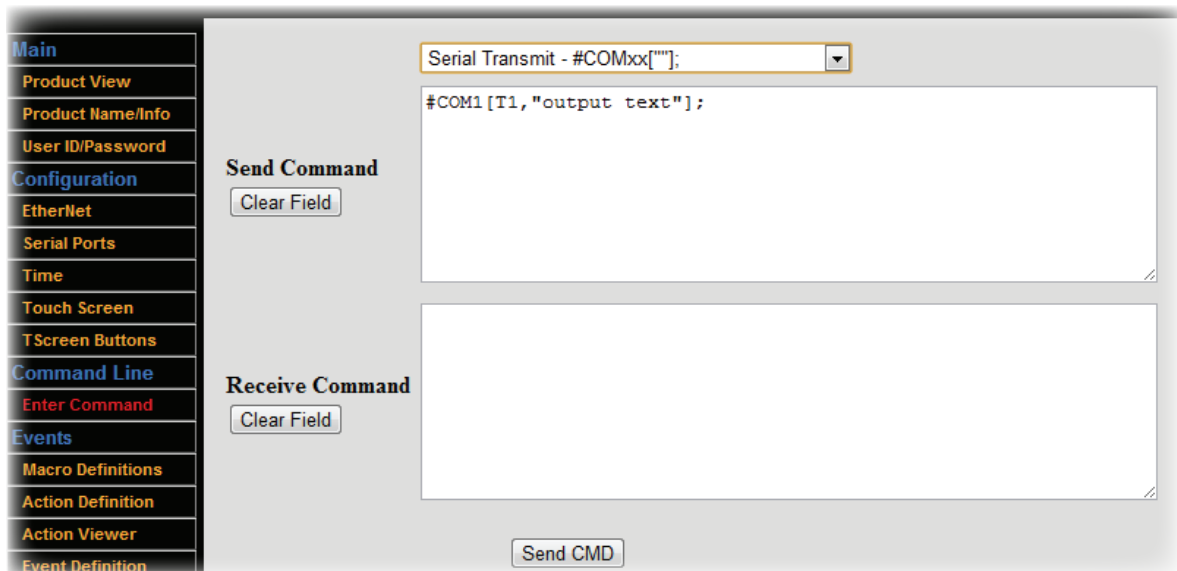

Appendix B: Creating Your Own User Interface

You can use the CB6000 to its full potential by learning to program your own configuration files. Each CB6000 includes a utility for creating, modifying, loading, and/or saving the configuration file. We strongly recommend that you use the following workflow for any custom programming:

1. Create Macros (covered in Appendix A.2) — Variables that refer to specific IP-addressable devices
2. Create Actions (covered in Appendix A.3) — Specific control commands for specific devices
3. Create Events (covered in Appendix A.4) — The kinds of situations in which you want to initiate one or more Actions
4. Create Pages (covered in Appendix B.2) — Logical groupings of buttons (e.g., DVD transport controls)
5. Create Buttons (covered in Appendix B.2) — Buttons that represent specific Events (e.g., mute)
6. Set Preferences (covered in Appendix C) — Set other parameters (e.g., timeout, security)

You can certainly deviate from this workflow, but you will probably waste some time flipping back and forth between programming screens unnecessarily.

1. Connect to the CB6000 through A Web Browser

On a computer connected to the LAN, type in the IP address of your CB6000 — the default is 192.168.1.104. If you have not already reassigned it (see **Step 3** for guidance).

2. Creating and Assigning Actions to Pages and Buttons

- Choose **TScreen Buttons**

You can create up to five different pages to help you nest or logically group various buttons. To work on a particular page:

- Click one of the **Page** buttons in the left column of the button definition interface

There are 8 available button slots on each page you create. These slots are displayed in the definition interface in the arrangement in which they will appear on the CB6000 touch screen. Below each slot is a useful shorthand to help you quickly review what each button has been assigned to do in the format:

[event number] -> [jump-to page number] ([repeat or delay time])

An 'x' indicates 'no action' — e.g., x-> 2(0) means 'No event, but jump to page 2 immediately'

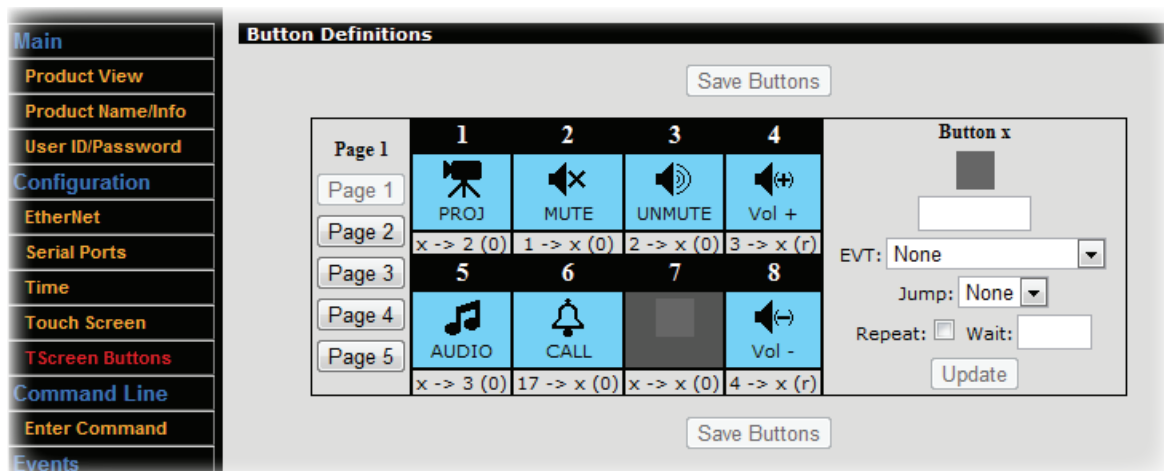

To create or edit a button:

- Click a button slot. Details for the selected button will appear in the right-hand section of the definition interface.

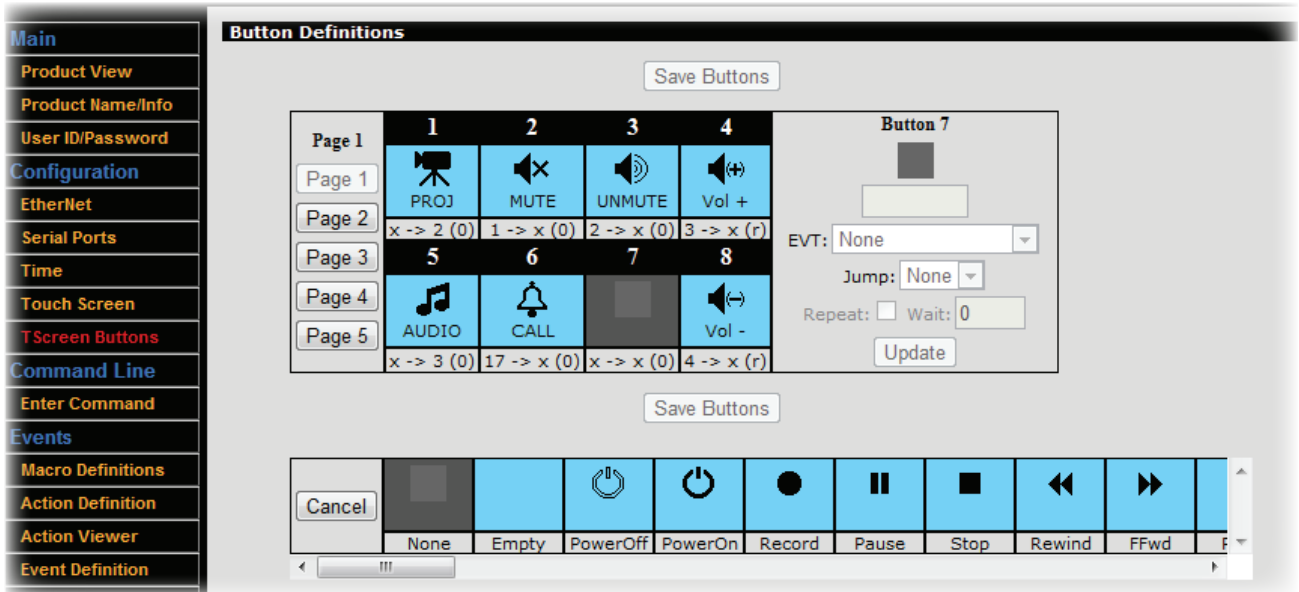

- Select an icon for the button. Click the graphic at the top of the button detail section, then click on an appropriate icon from the library that appears at the bottom of the screen

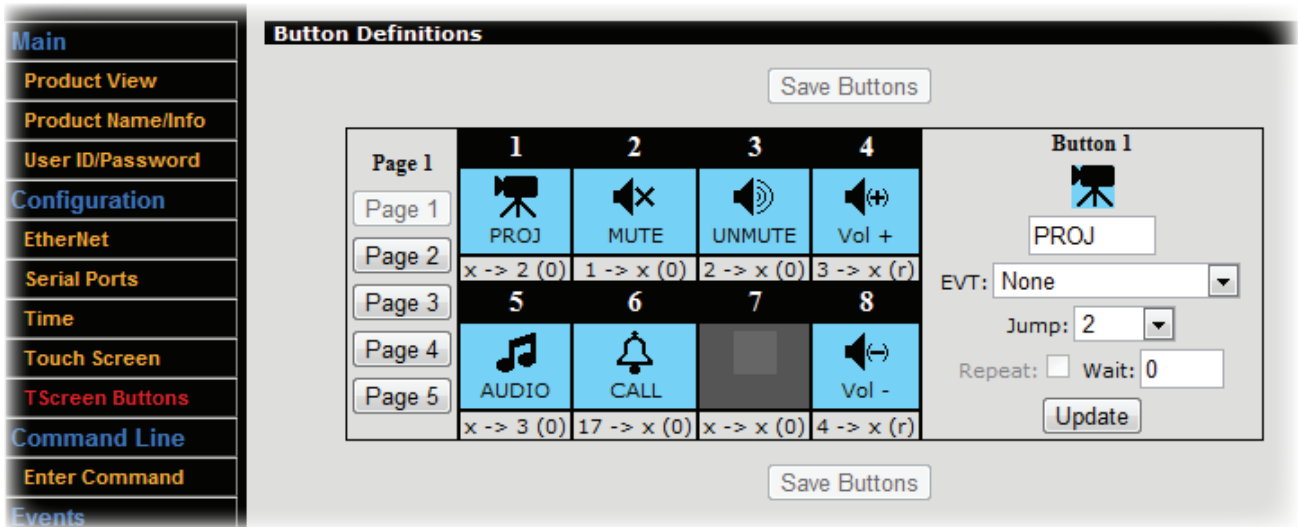

- Give the button a short text label that will appear on the touch screen. Click in the text field just below the graphic in the button detail section and choose an appropriate descriptor, ideally five characters or less.
- Choose:
 - To have the button trigger an Event, using the **EVT** drop-down. Ideally, you will have already defined these Events in Appendix A.4; however, you can define the Event details later as long as you note the Event number you're assigning here.
 - And/or, select the number of the page to which the display should jump in the **Jump** drop-down list
- If desired, choose to **Repeat** or to delay the action by setting a **Wait** time (note that jumps can't be repeated)
- Click **Update** to see your changes reflected in the definition interface layout

- Click **Save Buttons** to write the changes to the Base Configuration File. **IMPORTANT: Click Save Buttons before working on a different page or your changes will be lost!**
- Test your changes on the CB6000 user interface to be sure the results are as expected
- When you are satisfied that you have completely finished programming your Base Configuration File, see **Save/Restore** in Appendix C.8.

Appendix C: Setting Preferences

You can use the CB6000 to its full potential by learning to program your own configuration files. Each CB6000 includes a utility for creating, modifying, loading, and/or saving the configuration file. We strongly recommend that you use the following workflow for any custom programming:

1. Create Macros (covered in Appendix A.2) — Variables that refer to specific IP-addressable devices
2. Create Actions (covered in Appendix A.3) — Specific control commands for specific devices
3. Create Events (covered in Appendix A.4) — The kinds of situations in which you want to initiate one or more Actions
4. Create Pages (covered in Appendix B.2) — Logical groupings of buttons (e.g., DVD transport controls)
5. Create Buttons (covered in Appendix B.2) — Buttons that represent specific Events (e.g., mute)
6. Set Preferences (covered in Appendix C) — Set other parameters (e.g., timeout, security)

You can certainly deviate from this workflow, but you will probably waste some time flipping back and forth between programming screens unnecessarily.

1. Connect to the CB6000 through A Web Browser

On a computer connected to the LAN, type in the IP address of your CB6000 — the default is 192.168.1.104 If you have not already reassigned it (see Step 3 for guidance).

2. Name Your CB6000

- Choose **Product Name/Info > Custom Device Name**
- Enter a recognizable name for easier identification on the network
- Click **Save Setting**

The screenshot shows the frontrow web interface. At the top, it says "Running (since 18 Jan 2012, 11:27)" and "Exupery Elementary Room 7 CB6000". On the left is a navigation menu with items like "Main", "Product View", "Product Name/Info", "User ID/Password", "Configuration", "EtherNet", "Serial Ports", "Time", "Touch Screen", "TScreen Buttons", "Command Line", "Enter Command", and "Events". The main content area is titled "CB-6000 Device Name" and contains a form for "Custom Device Name" with the value "Exupery Elementary Room 7 CB6000" and a "Save Setting" button. Below that is "System MAC Address" with the value "00:04:a3:1a:8e:e7". At the bottom is "System Firmware Information" with "Control firmware version" as "0.0.2.6" and "Control firmware build" as "Dec 13, 2011".

3. Web Access Password

To set a password to deter configuration changes by network hacks:

- Choose **User ID/Password**
- Type in the old password (the default is 'calypso')
- Enter/re-enter the new password
- Click **Save Settings** in the top section
- Select *Admin* from the **Security Level** drop-down
- Click **Save Settings** in the bottom section

The screenshot shows a web interface with a sidebar menu on the left containing items like Main, Product View, Configuration, Ethernet, Serial Ports, Time, Touch Screen, TScreen Buttons, Command Line, Enter Command, Events, and Macro Definitions. The main content area is divided into two sections: 'System Password Update' and 'System Security'. The 'System Password Update' section includes a dropdown for 'Set Password for:' (set to 'admin'), input fields for 'Old Password:', 'New Password:', and 'Re-enter New Password:', and a 'Save Settings' button. The 'System Security' section includes a 'Security Level:' dropdown (set to 'None') and a 'Save Setting' button.

4. Advanced Ethernet Settings

- Choose **Ethernet**. As needed, make the following communication settings adjustments:
 - Automatic IP Configuration (DHCP): Use only if you are thoroughly familiar with DHCP configuration
 - IP Address
 - IP Subnet Mask (for your computer network grouping; default is 255.255.255.0)
 - Router IP Address of your subnet
 - Primary NameServer IP Address (default is 192.168.1.1)
 - Secondary NameServer IP Address
- Click **Save Settings** in the top section

The screenshot shows a web interface with a sidebar menu on the left containing items like Main, Product View, Configuration, Ethernet, Serial Ports, Time, Touch Screen, TScreen Buttons, Command Line, Enter Command, Events, Macro Definitions, Action Definition, Action Viewer, Event Definition, Event Viewer, Utilities, and Save/Restore. The main content area is divided into three sections: 'Device network configuration', 'Device port configuration', and 'System MAC Address'. The 'Device network configuration' section includes a checkbox for 'Automatic IP configuration (DHCP)' (unchecked), and input fields for 'IP Address' (192.168.1.104), 'IP Subnet Mask' (255.255.255.0), 'Router IP Address' (192.168.1.1), 'Primary NameServer IP Address' (192.168.1.1), and 'Secondary NameServer IP Address'. The 'Device port configuration' section includes input fields for 'Web Server Port' (80), 'Remote Management Port' (7262), and 'Remote Port Idle Timeout (mins)' (Disabled dropdown, 10 input). The 'System MAC Address' section includes a 'MAC Address' field (00:04:a3:1a:8e:e7). Each section has a 'Save Settings' button.

The device port configuration and System MAC Address sections consist of defaults generally not required for modification. The Web Server Port (set at 80) is also static and is visible here for informational purposes only. Next, the Remote Management Port is a Controller Network Action Protocol (CNAP) registered port set at 7262 for command-line (CNAP) functions only. It is used by external software to send commands to the controller. The Remote Port Idle Timeout field's default setting is Disabled. When active, it sets the duration (in minutes) before the controller releases the remote communication port after a period of inactive controller communication. If a special case arises where your system does require configuration, contact FrontRow Technical Services at customercare@gofrontrow.com for assistance.

5. Advanced Serial Port Settings

- Choose **Serial Ports**. The current settings can be viewed at the bottom of this web page. As needed, make the following port setting adjustments (e.g., as needed for controlling a specific projector):
 - COM Port number (default is 1)
 - Baud Rate (default is 19200)
 - Stop Bits (default is 1 Bit)
 - Parity (default is No Parity)
- Click **Save Settings**

COM Port	Baud Rate	Stop Bits	Parity	Mode
1	19200	1	None	RS232
2	19200	1	None	RS232

6. Set the Time

- Choose **Time**
- Either type the data into the fields provided or press the **Load Computer Time** button to retrieve the computer's current time/date.
- To enable (or disable) the Day Light Saving (DST) mode, click the box to **Honor the Daylight Saving Transition Table**. A message below the check box indicates whether DST is currently OFF or ON. A three-column table at the bottom of the view displays the current defined year and the next three years. No actual DST data can be changed with this interface. Contact FrontRow Technical Service at customercare@gofrontrow.com for DST modifications.
- Check the option box **Display clock in 24-hour format** to have the time displayed in the 24 hour format (if not checked, the time will be displayed in a 12 hour format).
- Click **Save Settings**

Year	Date ON	Date OFF
2012	Mar 11	Nov 4
2013	Mar 10	Nov 3

7. Customize Touch Screen Behavior

- Choose **Touch Screen**
- a. Select the desired behavior for dimming the screen between screen touches under **Dim Mode:**
 - *Disabled* (i.e. the screen will never dim)
 - *50% Dim* (the screen dims slightly)
 - *Max Dim* (the screen dims but the detail is still visible)
 - *Screen Off* (the screen goes completely dark)
- Enter the delay in minutes between a screen touch and entering dim mode under **Timeout Period**
- Click **Save Settings** in the top section
- b. Select the conditions upon which the CB6000 will 'fall back' to a default screen under **Fallback Mode:**
 - *None* (i.e. the screen will never change from the last screen used)
 - *On Timeout* (the screen will change after a defined period of inactivity)
 - *On Main Home Press* (the screen will only change if the user presses the page 1 Home button)
 - *On Either* (the screen will change either upon pressing the page 1 Home button or upon a defined period of inactivity)
- Select the screen that the CB6000 will 'fall back' to between screen touches **Fallback Screen:**
 - *Current* (when Panel Lock is enabled below, transitions to the unlock keypad screen; otherwise, no transition occurs)
 - *Clock Screen* (a large clock)
 - *Info Screen* (the text screen descriptor page; often used for the institution's name)
 - *Splash Screen* (the graphic screen; often used for the institution's logo)
- Enter the delay in minutes between the last screen touch and changing to a default screen under **Timeout Period**
- Click **Save Settings** in the middle section
- c. The panel buttons can also be locked to prevent tampering.
 - Check **Panel Lock Enable**
 - Set a **Password** for unlocking the panel (the default is 1357; must be a 4-digit odd number)
 - Click **Save Settings** in the bottom section

The screenshot displays the configuration interface for the CB6000 touch screen. On the left is a vertical navigation menu with categories: Main, Configuration, Events, and Utilities. The 'Touch Screen' option is highlighted in red. The main content area is divided into three sections:

- Touch Screen Power/Dim:** Dim mode is set to 'Screen Off' (dropdown). Timeout period is 10 minutes (input field). A 'Save Settings' button is present.
- Touch Screen Fallback:** Fallback mode is 'On either' (dropdown). Fallback screen is 'Splash screen' (dropdown). Timeout period is 10 minutes (input field). A 'Save Settings' button is present.
- Touch Panel Security:** Panel Lock enable is unchecked (checkbox). Password is 1357 (input field). A 'Save Settings' button is present.

You can also use the **Lock/Unlock Now** buttons to test the behavior or initiate modes remotely.

8. Save/Restore

Use this window to either load an existing configuration file onto your CB6000 or save the current configuration to a file on your computer for re-use as a template for other CB6000 units

To load an existing configuration file onto your CB6000:

- Select **Save/Restore**
- Select **Browse** and locate your Base Configuration File for this CB6000
- Check the check box if you want the IP address contained in the loaded configuration file to overwrite the IP address on your connected CB6000 unit.
- Click **Load**

Note that other operations such as IP address definition are often required. See **Step 4**.

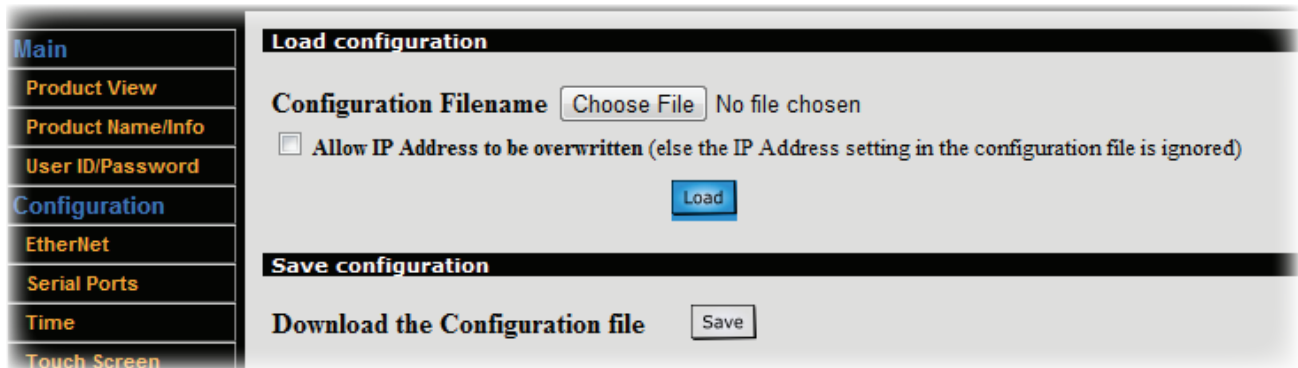

The screenshot shows a web-based configuration interface. On the left is a vertical navigation menu with the following items: Main (highlighted in blue), Product View, Product Name/Info, User ID/Password, Configuration (highlighted in blue), EtherNet, Serial Ports, Time, and Touch Screen. The main content area is divided into two sections. The top section is titled 'Load configuration' and contains a 'Configuration Filename' field with a 'Choose File' button and the text 'No file chosen'. Below this is a checkbox labeled 'Allow IP Address to be overwritten (else the IP Address setting in the configuration file is ignored)'. At the bottom of this section is a blue 'Load' button. The bottom section is titled 'Save configuration' and contains the text 'Download the Configuration file' followed by a 'Save' button.

To save your current configuration file to use as a template for other CB6000s:

- Select **Save/Restore**
- Click **Save**
- To save your configuration file to a specific folder, right-click on the **Save** button and choose Save Target As... or Save Link As... depending on your browser

Appendix D: CM3000 Commands

The following commands can be used in Actions to control how a FrontRow CM3000 amplifier/switch handles audio:

CM3000 Audio Commands*				
Syntax: #AUDn[Input,Mute,Volume];				
Name	Required/Optional	Data Type	Format	Description
<i>n</i>	Required	Constant	1	Denotes the sub-device. Since CM3000 has only one sub-device, this is always 1.
<i>Input</i>	Optional	Variant	<i>ICommand</i> where <i>Command</i> is an integer from 1 to 4, +, or -	Switches the audio input to: <ul style="list-style-type: none"> the channel corresponding to the integer used; the next higher channel (+); or the next lower channel (-)
<i>Mute</i>	Optional	Variant	<i>MCommand</i> where <i>Command</i> is 0, 1, or +	Audio mute: <ul style="list-style-type: none"> off (0); on (1); or toggle (+)
<i>Volume</i>	Optional	Variant	<i>VCommand</i> where <i>Command</i> is an integer from 1 to 100, +, or -. The + or - may be followed by a single digit (1-9) indicating the change in volume steps to be made.	Sets the audio volume to: <ul style="list-style-type: none"> the percentage of maximum volume corresponding to the integer used; an increase in volume (+) by <i>n</i> steps (+<i>n</i>); or a decrease in volume (-) by <i>n</i> steps (-<i>n</i>)
<p>Examples: Unmute and increase volume: #AUD1[M0,V+]; Unmute and decrease volume by 2 steps: #AUD1[M0,V-2]; Set volume to 10% of maximum: #AUD1[V10]; Mute: #AUD1[M1]; Unmute: #AUD1[M0]; Toggle mute: #AUD1[M+]; Switch to input 3, unmute, and set volume to 25 of maximum: #AUD1[I3,M0,V25]; Query current settings (returns value of input, mute, and volume): #AUD1[];</p>				

*For complete programming guidance, refer to the Calypso Action Control Language (CACL) manual under the Downloads section of the ezRoom web page: www.gofrontrow.com/ezroom.

Appendix E: CA1000 Commands

The following commands can be used in Actions to control how a FrontRow CA1000 amplifier handles audio:

CA1000 Audio Commands*				
Syntax: #Command\r				
Name	Required/Optional	Data Type	Format	Description
Command	Required	Variants	ACHn where n is an integer from 1 to 4	Switches the audio input to the channel corresponding to the integer used
			ACF	Switches the audio input to the next higher channel
			ACR	Switches the audio input to the next lower channel
			AVIn where n is an integer from 1 to 2	Increases volume by n steps. If you leave the argument n blank, a default of 1 is assumed.
			AVDn where n is an integer from 1 to 2	Decreases volume by n steps. If you leave the argument n blank, a default of 1 is assumed.
			BVIn where n is an integer from 1 to 2	Unmutes and increases volume by n steps. If you leave the argument n blank, a default of 1 is assumed.
			BVDn where n is an integer from 1 to 2	Unmutes and decreases volume by n steps. If you leave the argument n blank, a default of 1 is assumed.
			AVMn where n is blank, 0, or 1	Audio mute: <ul style="list-style-type: none"> • on (0); • off (1); or • toggle (blank)
			AVAn where n is an integer from 1 to 32	Sets absolute volume to level indicated by n.
			BVAn where n is an integer from 1 to 32	Unmutes and sets absolute volume to level indicated by n.
			AVA?	Queries current volume level. Returns integer from 1 to 32.
			ACH?	Queries current input channel. Returns integer from 1 to 4.
			AVM?	Queries current mute status. Returns 0 or 1.
Examples: Switch to input 3: #ACH3\r Switch to next lower input channel: #ACR\r Unmute and increase volume: #BVI\r Unmute and set volume to 14: #BVA14\r Mute: #AVM0\r				

*For complete programming guidance, refer to the Calypso Action Control Language (CACL) manual under the Downloads section of the ezRoom web page: www.gofrontrow.com/ezroom.

Appendix F: Troubleshooting

The buttons on the touch screen are not responsive enough

- Recalibrate the screen using a fine stylus. On the screen (see Step 1.2) go to Menu > Calib > Enter Code (default code is 1538) and follow the instructions.

I can't remember what IP address I changed the CB6000 to, and now I can't communicate with it

- Reset the CB6000 to its default IP address (192.168.1.104). On the screen (see Step 1.2) go to Menu > Reset > Enter Code 1538 and follow the instructions. Note that this action also resets the web access password to 'calypso' (see Appendix C.3).

I can't remember what web access password I set for the CB6000, and now I can't log onto it

- Reset the CB6000 to its default web access password ('calypso'). On the screen (see step 1.2) go to Menu>Reset>enter code 1538 and follow the instructions. Note that this action also resets the CB6000's IP address (see Appendix C.4).

I've connected a new CB6000 to my computer for configuration but can't communicate with it

- If you are using a Windows® computer, clear the ARP cache. From the command prompt, enter: ARP -D IPADDRESS (e.g., ARP -D 192.168.1.104)



Installer Assistance: www.gofrontrow.com

USA/Global

1690 Corporate Circle
Petaluma, CA 94954-6712
United States
toll-free: 800.227.0735
tel: 707.769.1110
fax: 707.769.9624
www.gofrontrow.com

Canada

6950 Creditview Road,
Unit 1
Mississauga, ON L5N 0A6
Canada
toll-free: 800.340.9894
tel: 905.461.5300
www.gofrontrow.com

Australia

629 Nudgee Road
Nundah QLD 4012
Australia
tel: 1 800 746 642
fax: 1300 737 983
www.gofrontrow.com

Scandinavia

Kongebakken 9
2765 Smørum
Denmark
tel: +45 3917 7101
fax: +45 3927 7900
www.gofrontrow.com